

TOPPING
Professional

E4x4 Pre

Model: TPP504
V1.1

使用手册 

User Manual 

目录

1. 包装内物品清单	1	5. TOPPING Professional Control Center	4	8. 注意事项	5
2. 产品基本属性	1	6. DAW的音频设置	4	9. 参数	6
3. 部件与名称	2	7. 故障排除	5	话筒输入	6
前面板	2	无法开机	5	线路输入	6
后面板	3	无声音	5	高阻抗输入	6
恢复出厂设置	3	录制的声音太大，太小或听不到	5	线路输出	6
4. 连接	4	声音间断	5	耳放输出	6
连接	4	输入端的声音失真	5		
PC端模式&移动端模式	4	无法播放或者录制	5		

包装内物品清单

1. 包装内物品清单

E4x4 Pre 主机	x 1
USB A-C 数据线	x 1
USB C-C 数据线	x 1
6.35mm 转 3.5mm 转接头	x 1
产品入门指南	x 1



2. 产品基本属性

尺寸	29.2cm x 12.9cm x 5.0cm (包含突出部分)
单机重量	830g
供电	USB TypeC 接口 (DC5V/1.0A)
接口类型	USB 2.0
话筒输入	4 路 (复合座子, 带48V幻象电源)
高阻抗输入	2 路 (复合座子)
线路输入	4 路 (复合座子)
线路输出	4 路
耳机接口	2 个
直接监听	有 (可调节监听混合比)
输入电平指示	有 (4x8 LED 灯)
输出电平指示	有 (4x8 LED 灯)
话放技术	Ultra-linear
耳放技术	NFCA-LE
支持采样率	24bits/44.1kHz-24bits/192kHz
软件控制	有 (TOPPING Professional Control Center)
DAW 通道	8 个
内录通道	6 个
操作系统	Mac/Win/iOS/Android
电源开关	有

3. 部件与名称

前面板

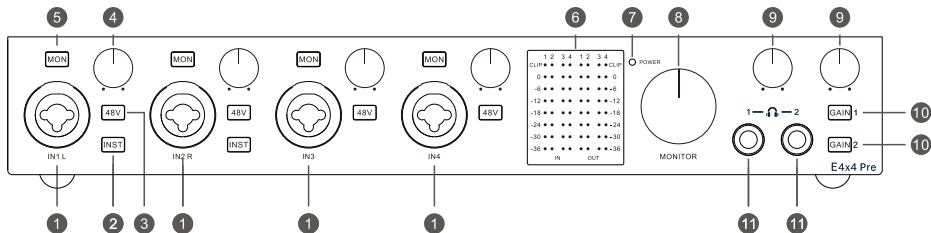

1. 输入接口

IN1&IN2: 用于连接麦克风、线路输出设备、乐器（例如电吉他）。

IN3&IN4: 用于连接麦克风或线路输出设备，不支持连接乐器。

该组合接口支持XLR插头，6.35mm TRS平衡插头和6.35mm TS单端插头。

麦克风：使用XLR线连接

线路输出设备：使用6.35mm TRS线连接

乐器：使用6.35mm TS线连接

2. INST

线路/乐器输入切换。按钮灯熄灭时为线路输入，按钮灯点亮时为乐器输入。

3. 48V

48V幻象电源开关，按钮灯亮时开启幻象电源供电，作用于对应输入接口的XLR输入。

▲ 特别注意：

- 一般是电容式麦克风需要幻象电源。不需要幻象电源的麦克风或其他设备，如果使用幻象电源，可能会造成损坏。所以在不需要使用幻象电源时将其关闭。如需开启，请确保您的麦克风需要48V幻象电源。

- 在打开和关闭幻象电源之前，请先将E4x4 Pre的音量调低。

4. 输入增益旋钮

用于调节麦克风、乐器或线路输入信号的增益大小，逆时针旋转减小，顺时针旋转增大。调节增益时请观察LED电平表，削波时，即红灯亮起时，适当减小增益。

5. MON

直接监听开关。按压并点亮该按键会启用直接监听，将该通道的输入信号直接路由到耳机输出，并将单声道信号同时输出到左右声道，这样可以实现零延迟地监听输入信号。

6. LED电平指示

IN1~4是输入电平指示，OUT1~4是输出电平指示。

当信号被削波时，电平表顶部的CLIP指示灯会亮起，此时请降低信号电平。

7. 电源指示灯

灯常亮：工作状态

灯熄灭：关机状态

呼吸灯：待机状态

当E4x4 Pre的自动待机打开后，如果检测到电源信号存在，而USB信号，模拟输入信号

（IN1~IN4）均不存在，则会作出提示（指示灯闪烁）并且在一分钟后进行待机状态。一旦检测到USB信号存在，就会自动恢复为正常工作状态。

自动待机功能需要在TOPPING Professional Control Center的 ⚙️ 内设置。

8. MONITOR

该旋钮调节后面板LINE OUT接口1和2的信号电平大小。逆时针旋转减小，顺时针旋转增大。

9. 耳机音量旋钮

左右两个旋钮分别控制耳机接口1和2的音量大小。逆时针旋转减小，顺时针旋转增大。

10. GAIN

耳机增益设置。按钮灯熄灭时为低增益，按钮灯点亮时为高增益。

11. 6.35mm单端耳机接口

配备6.35mm转3.5mm的转接头，适用于6.35mm和3.5mm插头的耳机。

后面板

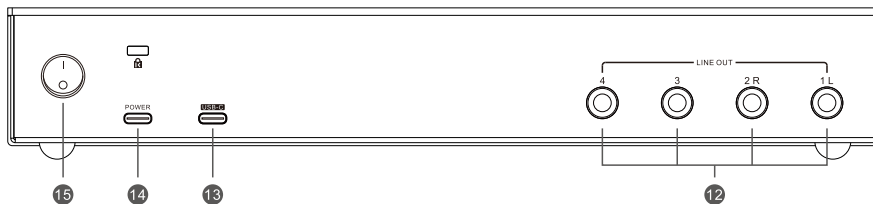

12. LINE OUT

6.35mm TRS平衡接口，用于连接主监听设备或线路输入设备。

13. USB-C

连接电脑/手机/平板到该接口，用于进行数据传输以及给E4x4 Pre供电。

14. POWER

当供电不足，特别是连接手机/平板时，请连接DC5V电源到此接口。此时右侧的USB-C接口不再用作供电，仅用于数据传输。

15. 电源开关

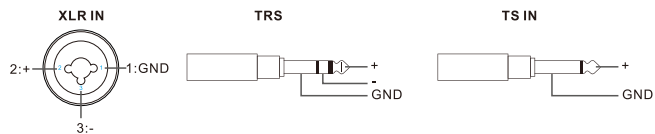

恢复出厂设置

上电的同时按住左上角的MON按钮直到电平表的指示灯全部亮起，即可恢复出厂设置。

4. 连接

连接

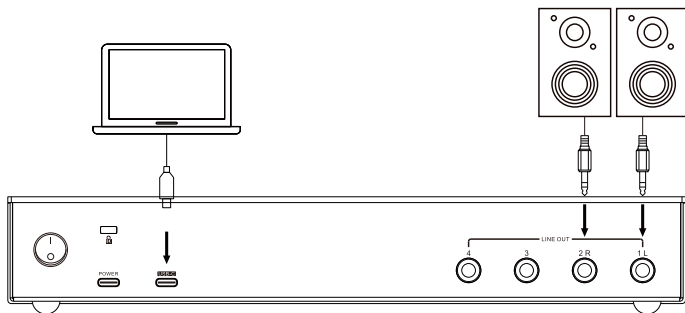
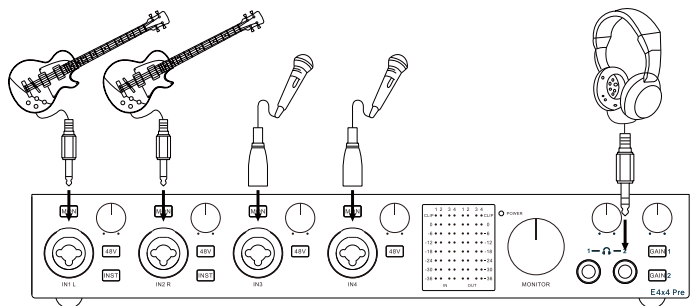

连接和断开其他设备之前，请先将E4x4 Pre的音量调到最小，以免过大音量损害听力或损坏其他设备。

PC端模式&移动端模式

连接电脑请设置为PC端模式，连接手机/平板请设置为移动端模式。

上电的同时按住IN1的48V按键即可进入设置，再次按压IN1的48V按键，可切换PC端模式（亮8个灯）和移动端模式（亮4个灯），设置断电重启后生效。

5. TOPPING Professional Control Center（下文简称为ToppingPro）

点击该链接 <https://www.topping.pro/downloads/TOPPING Professional Control Reference Guide.pdf> 下载详细的ToppingPro使用指南。

6. DAW的音频设置

E4x4 Pre兼容任何在Mac上支持Core Audio和在Windows上支持ASIO的DAW宿主软件。

您需要确保在DAW的设置中，将E4x4 Pre设置为使用ASIO驱动（Windows）或者Core Audio驱动（Mac）的设备。如果您不了解如何进行设置，请参考您的DAW的用户手册。

7. 故障排除

无法开机

1. 检查并且将后面板的电源开关切换到电源开。
2. 可能是供电不足导致的，请尝试连接DC5V电源到E4x4 Pre的电源输入接口。
3. 检查USB线是否损坏了，尝试使用其他长度不超过2米的USB线。
4. 尝试使用电脑的其他USB口。最好使用电脑主机背后的USB口。
5. 检查是否是电脑的问题，如果条件允许，试试接其他的电脑。

无声音

1. 检查和音箱的连接以及音箱的设置。
2. 调节E4x4 Pre输出的音量。
3. 检查ToppingPro的设置。
4. 尝试USB直接连接到电脑，而不经过USB hub。
5. 断开连接到电脑上的闲置的USB设备。
6. 关闭所有不使用的应用程序。

录制的声音太大，太小或听不到

1. 调节E4x4 Pre的输入增益旋钮。
2. 注意当连接到需要48V幻象电源供电的麦克风，需要开启幻象电源供电。
3. 检查ToppingPro的设置。

声音间断

1. 将ToppingPro(仅Windows)和播放软件上的缓冲大小调大。
2. 检查是否是电脑的问题,如果条件允许,试试接其他的电脑。

输入端的声音失真

观察LED电平表，如果削波指示灯亮起，适当减小输入增益。

无法播放或者录制

1. 检查并确定已经在您使用的软件上将E4x4 Pre设置为输入和输出的设备。
2. 确保E4x4 Pre和电脑连接良好。
3. 将所有应用程序关闭，拔插连接电脑和E4x4 Pre的USB线，然后再重新尝试播放或录制。

USB不识别

1. 关闭全部的杀毒软件，重装ToppingPro。
2. 尝试连接DC5V电源到POWER接口。
3. 检查USB线是否损坏了，尝试使用其他长度不超过2米的USB线。
4. 尝试使用电脑的其他USB口。最好使用电脑主机背后的USB口。
5. 检查是否是电脑的问题，如果条件允许，试试接其他的电脑/手机。

8. 注意事项

1. 不得将本机搁置在高温、潮湿的环境，更不得淋雨或者受强烈冲击。
2. 不得随意拆开机壳，如需维修应请专业维修人员处理。
3. 本机仅供室内使用。
4. 对因产品的故障而直接或间接引起的任何损失或损坏不予负责。
5. 因产品改进，规格及功能若有变动恕不另行通知。

9. 参数 (@24bits/96kHz)

话筒输入

等效输入噪声 @A-wt,150 Ohm	-130.5dBu
总谐波失真加噪声 @A-wt	-110dB (0.0003%)
动态范围 @A-wt	115dB
信噪比 @A-wt	115dB
声道串扰 @1kHz	-140dB
频率响应	20Hz-40kHz (±0.2dB)
最大输入电平	8.6dBu
输入阻抗	1.5K Ohms
增益	58dB + 20dB (20dB数字增益)
幻象电源	48V
接口类型	复合座子的XLR接口

线路输入

总谐波失真加噪声 @A-wt	-107dB (0.00045%)
动态范围 @A-wt	115dB
信噪比 @A-wt	115dB
声道串扰 @1kHz	-140dB
频率响应	20Hz-40kHz (±0.1dB)
最大输入电平	23.9dBu
输入阻抗	9K Ohms
增益	58dB + 20dB (20dB数字增益)
接口类型	复合座子的TRS接口

高阻抗输入

总谐波失真加噪声 @A-wt	-108dB (0.0004%)
动态范围 @A-wt	115dB
信噪比 @A-wt	115dB
声道串扰 @1kHz	-140dB
频率响应	20Hz-40kHz (±0.3dB)
最大输入电平	14.8dBu
输入阻抗	1M Ohms
增益	58dB + 20dB (20dB数字增益)
接口类型	复合座子的TS接口

线路输出

总谐波失真加噪声 @A-wt	-100dB (0.001%)
动态范围 @A-wt	115dB
模拟动态范围 @A-wt, -40dB衰减	127dB
信噪比 @A-wt	115dB
声道串扰 @1kHz	-128dB
频率响应	20Hz-40kHz (±0.3dB)
最大输出电平	14dBu
底噪 @A-wt	1.8uVrms
输出内阻	100 Ohms
接口类型	6.35mm TRS平衡接口

耳放输出

总谐波失真加噪声 @A-wt	-100dB (0.001%)
动态范围 @A-wt	115dB
模拟动态范围 @A-wt, -40dB衰减	132dB
信噪比 @A-wt	115dB
声道串扰 @1kHz	-120dB
频率响应	20Hz-40kHz (±0.3dB)
最大输出电平	0dBu @ Gain=L 17dBu @ Gain=H
底噪 @A-wt	1 uVrms
输出内阻	1 Ohms
接口类型	6.35mm TRS立体声耳机接口
输出功率	580mW x 2 @32Ω THD+N<1% 380mW x 2 @64Ω THD+N<1% 198mW x 2 @150Ω THD+N<1% 105mW x 2 @300Ω THD+N<1% 55mW x 2 @600Ω THD+N<1%

*说明：以上数据是 TOPPING 实验室测试得到的结果。

Catalog

1. Contents list	1	5. TOPPING Professional Control Center	4	8. Precautions	5
2. Attribute	1	6. Audio Set-up in your DAW	4	9. Specifications	6
3. Parts and names	2	7. Trouble shooting	5	Microphone Inputs	6
Front panel	2	No power	5	Line Inputs	6
Rear panel	3	Playback sound cannot be heard	5	Instrument Inputs	6
Factory reset	3	Recorded audio is too loud, too quiet or silent	5	Line Outputs	6
4. Connection	4	Sound breaks up	5	Headphone Outputs	6
Connection	4	The sound of the device connected to the input jack is distorted	5		
Mobile mode/PC mode	4	Cannot play or record	5		

Contents list

1. Contents list

E4x4 Pre	x 1
Type A to Type C cable	x 1
Type C to Type C cable	x 1
6.35 mm to 3.5 mm adaptor	x 1
Quick Start Guide	x 1



2. Attribute

Measured	29.2cm x 12.9cm x 5.0cm (Include protruding parts)
Weight	830g
Power input	USB TypeC port (DC5V/1.0A)
USB protocol	USB 2.0
Microphone inputs	4x Combo connector (with 48V phantom power switches)
Instrument inputs	2x Combo connector
Line inputs	4x Combo connector
Line outputs	4x
Headphone output	2x
Zero-latency direct monitoring	Yes (Equipped with monitor mix knob)
Input meter	Yes (4x8 LED indicators)
Output meter	Yes (4x8 LED indicators)
Mic pre modules	Ultra-linear
Headphone amp modules	NFCA-LE
Supported sampling rates	24bits/44.1kHz-24bits/192kHz
Software Control	Yes (TOPPING Professional Control Center)
DAW channels	8x
Loopback channels	6x
OS support	Mac/Win/iOS/Android
Power switch	Yes

3. Parts and names

Front panel

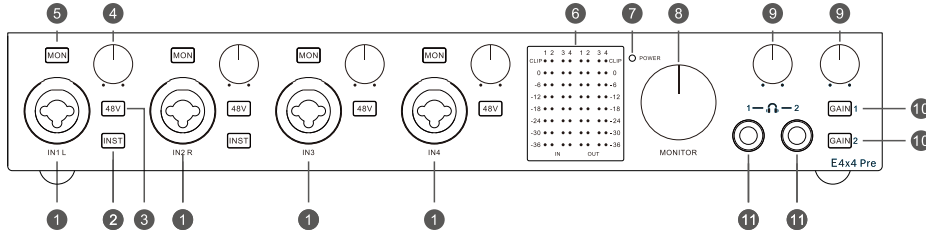

1. Inputs

IN1&IN2: For connecting microphones, line-level devices or instruments (e.g., guitar).

IN3&IN4: For connecting microphones, line-level devices. No support for connecting instruments.

These can be used with both XLR and 6.35mm (balanced or unbalanced) phone plugs. Microphones will normally be connected using XLR plugs. Instruments should be connected via 6.35mm TS plugs, and line-level devices should be connected via 6.35mm TRS plugs.

2. INST

Instrument/Line input switches for each input which alter gain and input impedance to suit either instrument or line level signals. Line in when the button light is off; instrument in when the button light is on.

3. 48V

48V phantom power switches for mic inputs. When light is on, E4x4 Pre enables 48V phantom power at corresponding XLR socket.

⚠ CAUTION:

- Phantom power is only required for condenser microphones and may damage the connected equipment that does not require it. Therefore, turn phantom power off when it is not required. Make sure if your microphone needs the 48V phantom power before turning it on.

- Set all volume levels to minimum before turning phantom power on or off.

4. Input gain knobs

Adjust the gain level of microphone, instrument or line input. Rotate counterclockwise to reduce the gain level and clockwise to increase the gain level. Watch the input meter while adjusting gain and reduce the gain level when red light is on (clipping).

5. MON

Press and light up the MON button to enable direct monitoring, which routes the channel's input signal directly to the left and right channels of the headphone output, so that you can monitor your input signals without any latency.

6. LED Meters

IN1-IN4 are the input meters and OUT1-OUT4 are the output meters.

If your signal is hitting CLIP (top red LED), which means it is clipping, reduce the signal level.

7. Power indicator

Solid light: Working state

Light off: Power off status

Breathing light: Standby state

When the automatic standby function is on, if power signal is detected while no USB signal, analog input signals (IN1-IN4) are present, the power indicator will flash and E4x4 Pre will enter standby state after one minute. Once having detected valid USB signal, it will automatically return to working state.

*Automatic standby setting is in the ⚙ of TOPPING Professional Control Center.

8. MONITOR

This knob affects the level sent out of LINE OUT 1&2. Rotate counterclockwise to decrease the volume and clockwise to increase the volume.

9. Headphone volume control

The left and right knobs control the volume level of headphone jacks 1 and 2 respectively. Rotate counterclockwise to decrease the volume and clockwise to increase the volume.

10. GAIN

Headphone amp gain setting. Low gain when the button light is off; high gain when the button light is on.

11. 6.35mm headphone output jacks

Connect your headphones here.

Parts and names

Rear panel

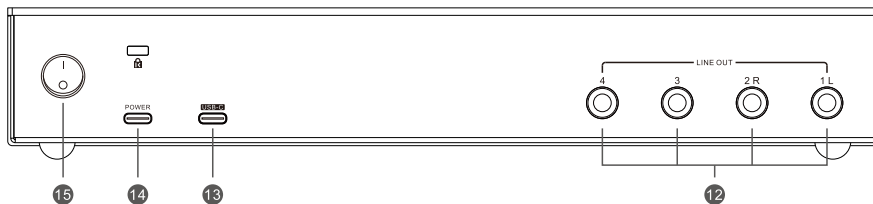

12. LINE OUT

6.35mm TRS balanced jacks. For connecting to active speakers or amplifier.

13. USB-C

Connect the E4x4 Pre to a computer/tablet/mobile phone via the provided USB cable. This connection also powers the E4x4 Pre depending on the power supply of your USB port.

14. POWER

Connect to a DC5V power supply if your USB port can't provide enough power, especially when you connect a mobile phone/a tablet. Then, the USB-C port beside it is no longer used for power input, only for data transmission.

15. Power switch

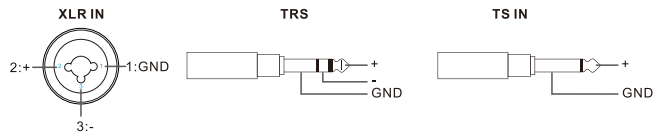

Factory reset

Press and hold the **MON** button at the top left corner while powering on the device until all meter indicators light up, and the factory settings can be restored.

4. Connection

Connection

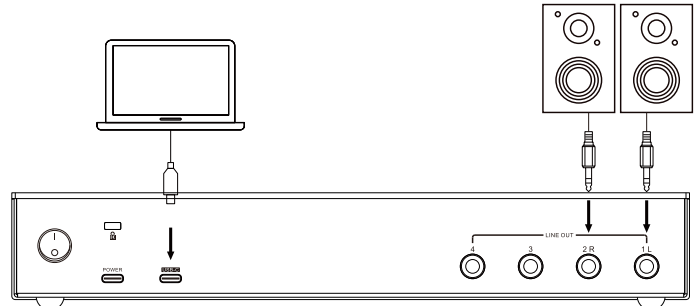
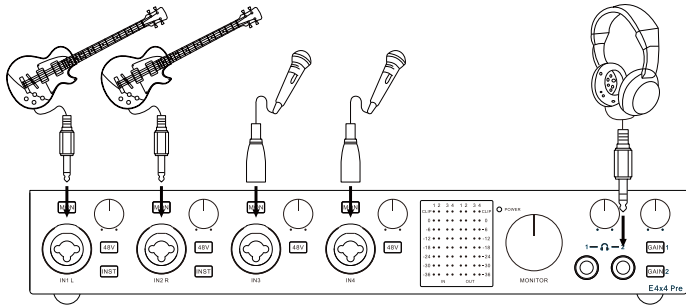

Make sure to set all volume levels to minimum before connecting or disconnecting the external device. Otherwise, high-volume output may damage your hearing or equipment.

Mobile mode/PC mode

Press and hold the 48V button of IN1 while powering on the device to enter the setup.

Press the same 48V button again to switch modes. 8 lights on is PC mode; 4 lights on is mobile mode. Power off and reboot to save setting.

5. TOPPING Professional Control Center (hereinafter called the “ToppingPro”)

Please download the reference guide of TOPPING Pro from <https://www.topping.pro/downloads/TOPPING Professional Control Reference Guide.pdf>.

6. Audio Set-up in your DAW

E4x4 Pre is compatible with any DAWs that supports Core Audio on Mac or ASIO on Windows.

You need to ensure that E4x4 Pre is selected as the ASIO driver (Windows) or Core Audio driver (Mac) in the DAW's preferences/playback settings. If you are not sure where these options can be found, please refer to your DAW's user guide.

7. Trouble shooting

No power

1. Check if the rear panel power switch is in the ON position.
2. It may be caused by insufficient power supply, please try to connect DC5V power supply to the power input.
3. Confirm if the USB cable is broken or damaged, replace the USB cable with a new one. Use a USB cable no longer than 2 meters.
4. Try with other USB ports of your computer.
5. Check if the problem is on the computer. Try with another one.

Playback sound cannot be heard

1. Check the speaker connections and the volume settings on the speakers.
2. Adjust the E4x4 Pre Line output and headphone amp output volume.
3. Check the settings on the ToppingPro.
4. Connect E4x4 Pre and your computer directly without using a USB hub.
5. Remove the USB devices which are connected with your computer and not in use, and then confirm the sound.
6. Quit all applications you are not using then confirm the sound.

Recorded audio is too loud, too quiet or silent

1. Adjust the E4x4 Pre input gain level.
2. When using the condenser mic which needs 48V phantom power, turn phantom power on.
3. Check the settings on the ToppingPro.

Sound breaks up

1. Set the buffer size (latency) in the audio application that you are using or in ToppingPro to a larger value (Windows only).
2. Check if the problem is on the computer. Try with another one.

The sound of the device connected to the input jack is distorted

Watch the input meter and reduce the input gain level if clipping indicator is on.

Cannot play or record

1. Confirm that E4x4 Pre is set for input and output in the software that you are using.
2. Confirm that the E4x4 Pre is connected to the computer correctly.
3. Quit all the software that is using the E4x4 Pre, and unplug and re-plug the USB cable connected to the E4x4 Pre.

The computer does not recognize this unit

1. Turn off all antivirus applications and reinstall ToppingPro.
2. Try connecting a DC5V power supply to POWER port.
3. Confirm if the USB cable is broken or damaged, replace the USB cable with a new one. Use a USB cable no longer than 2 meters.
4. Try with other USB ports of your computer.
5. Check if the problem is on the computer. Try with another one.

8. Precautions

1. Do not keep the unit in a hot, humid environment or hit the unit strongly.
2. Opening the case instantly voids the warranty!
3. Indoor use only.
4. Topping accepts no liability for any loss or damage arising directly or indirectly from the failure of E4x4 Pre.
5. For improvement purpose, specifications subject to changes without prior notice.

9. Specifications (@24bits/96kHz)

Microphone Inputs

Equivalent Input Noise @A-wt, 150 Ohm	-130.5dBu
THD+N @A-wt	-110dB (0.0003%)
Dynamic Range @A-wt	115dB
SNR @A-wt	115dB
Crosstalk @1kHz	-140dB
Frequency Response	20Hz-40kHz (±0.2dB)
Maximum Input Level	8.6dBu
Input Impedance	1.5K Ohms
Available Gain	58dB + 20dB (20dB digital gain)
Phantom Power	48V
Connector Type	XLR connector of the combo socket

Line Inputs

THD+N @A-wt	-107dB (0.00045%)
Dynamic Range @A-wt	115dB
SNR @A-wt	115dB
Crosstalk @1kHz	-140dB
Frequency Response	20Hz-40kHz (±0.1dB)
Maximum Input Level	23.9dBu
Input Impedance	9K Ohms
Available Gain	58dB + 20dB (20dB digital gain)
Connector Type	TRS connector of the combo socket

Instrument Inputs

THD+N @A-wt	-108dB (0.0004%)
Dynamic Range @A-wt	115dB
SNR @A-wt	115dB
Crosstalk @1kHz	-140dB
Frequency Response	20Hz-40kHz (±0.3dB)
Maximum Input Level	14.8dBu
Input Impedance	1M Ohms
Available Gain	58dB + 20dB (20dB digital gain)
Connector Type	TS connector of the combo socket

Line Outputs

THD+N @A-wt	-100dB (0.001%)
Dynamic Range @A-wt	115dB
Analogue Dynamic Range @ A-wt, -40dB attenuation	127dB
SNR @A-wt	115dB
Crosstalk @1kHz	-128dB
Frequency Response	20Hz-40kHz (±0.3dB)
Maximum Output Level	14dBu
Noise @A-wt	1.8uVrms
Output Impedance	100 Ohms
Connector Type	6.35mm TRS balanced jack

Headphone Outputs

THD+N @A-wt	-100dB (0.001%)
Dynamic Range @A-wt	115dB
Analogue Dynamic Range @ A-wt, -40dB attenuation	132B
SNR @A-wt	115dB
Crosstalk @1kHz	-120dB
Frequency Response	20Hz-40kHz (±0.3dB)
Maximum Output Level	0dBu @ Gain=L 17dBu @ Gain=H
Noise @A-wt	1 uVrms
Output Impedance	1 Ohms
Connector Type	6.35mm stereo headphone jack
Output Power	580mW x 2 @32Ω THD+N<1% 380mW x 2 @64Ω THD+N<1% 198mW x 2 @150Ω THD+N<1% 105mW x 2 @300Ω THD+N<1% 55mW x 2 @600Ω THD+N<1%

*Note: The above data is the result of the test in TOPPING laboratory.